



# 产品承认书 SPECIFICATION FOR APPROVAL

客户名称:

CUSTOMER

我司料号:

OUR PART NO.

XREE16-250406

我司品名:

OUR PART NAME

Transformer

送样日期:

DATE SAMPLES

数量:

QUANTITY

## 制造确认 MANUFACTURER APPROVE

拟制 DRAWN	审核 CHECKED	确认 APPROVED
Hufangting	RaoPing	ZhongCuilan

## 客户确认 CUSTOMER APPROVE

客户名称 CUSTOMER NAME:

客户料号 CUSTOMER P/N:

规格型号 DESCRIPTION: EE16 vertical 5+5 1.35mH

检查结果:  合格  不合格

签名及盖章:

INSPECT RESULT ACCEPT REJECT

SIGNATURE AND STAMP

说明 REMARK:

如对本承认书内容有异议请提出或标记发送至我司, 本承认书在未收到异议回复时于本承认书提供一周后生效。

If you have any objection to the contents of this acknowledgment, please raise it or send the mark to us. The acknowledgment will become effective one week after the acknowledgment is provided in the absence of any objection.

东莞市祥如电子有限公司

DONGGUAN XIANGRU ELECTRONICS CO., LTD

Tel: 0769-86346548 Fax: 0769-86346358

Email: dgxiangru@126.com



## 产品承认书

### SPECIFICATION FOR APPROVAL

客户名称 CUSTOMER		日期 DATE	2025/1/17
客户物料编号 CUSTOMER P/N		客户规格型号 DESCRIPTION	EE16 vertical 5+5 1.35mH
我司物料编号 OUR PART NO	XREE16-250406	我司品名 OUR PART NAME	Transformer

#### 一、外观尺寸 Appearance of size

单位 Unit: mm

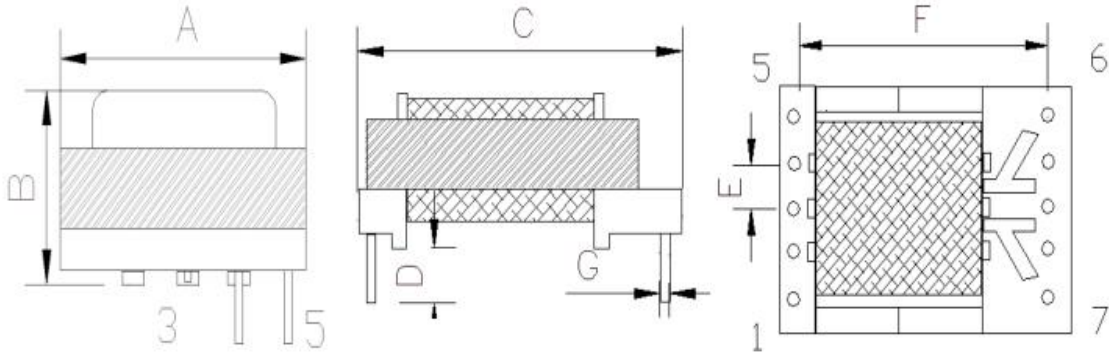

A	B	C	D	E	F	G
17.5max	15.0max	19.5max	3.5±0.5	3.25±0.3	15.5±0.5	0.7±0.1

(以上尺寸为手工测量只做参考详细尺寸以实物为准) (The above dimensions are measured by hand for reference only. The detailed dimensions are subject to the physical objects.)

#### NOTE:

1. 骨架为EE16卧式单边加长5+5，空PIN1.2.7.9.10脚，成品剪pin3脚2/3；PIN1-5朝机台右顺转绕制；Skeleton for the EE16 horizontal single-sided extension 5 +5, empty PIN1.2.7.9.10 feet, finished cut pin3 feet 2/3; PIN1-5 towards the machine right turn winding.
2. 磁芯EE16.5/15/5,材质PC40,需开气隙,气隙装于pin6-10脚边; Core EE16.5/15/5, material PC40, need to open the air gap, the air gap is installed in the pin6-10 feet edge.
3. 磁芯胶带用5.0mm胶带包2圈; 产品真空含浸处理; The core tape is wrapped with 5.0mm tape for 2 times; the product is vacuum impregnated.
4. 产品胶带颜色为淡黄色。Product tape color is light yellow.
5. 产品标签贴于脚边,内容: The product label is attached to the footer and contains. Marking 丝印: TR047; Datecod 周期;

#### SHEMATLCL:

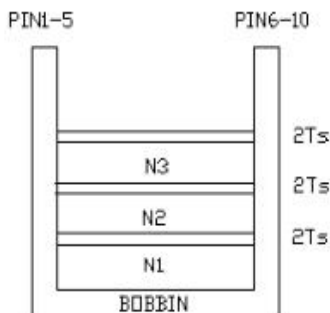

#### CONNECT:

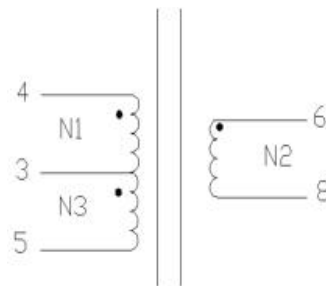

● 表示起绕端



## 产品承认书 SPECIFICATION FOR APPROVAL

客户名称 CUSTOMER		日期 DATE	2025/1/17
客户物料编号 CUSTOMER P/N		客户规格型号 DESCRIPTION	EE16 vertical 5+5 1.35mH
我司物料编号 OUR PART NO	XREE16-250406	我司品名 OUR PART NAME	Transformer

### 绕线结构 /WINDING STRUCTURE:

WDG	Pin S—F	Material	Turns	Tape	挡墙		套管		备注note
					PIN	TOP	S	F	
N1	4-3	2UEW Ø0.21mm*1P	68TS	9.0mm/2TS	/	/			密绕 winding
N2	6-8	2UEW Ø0.25mm*1P	70TS	9.0mm/2TS	/	/	22L*12mm	22L*12mm	
N3	3-5	2UEW Ø0.21mm*1P	77TS	9.0mm/2TS	/	/			

### 电气性能 /ELECTRICAL PROPERTIES (at 25°C) ):

半测电感 at 10KHZ 0.3V Half Measured Inductance at 10KHZ 0.3V				耐压测试 Pressure resistance test	绝缘电阻测试at DC500V Insulation resistance testat DC500V	圈数测试at 20KHZ 1V Lap Testat 20KHZ 1V	DCR测试25°C DCR test 25° C
foot position	minimum value	midpoint	maximum values				
4-5	1.30mH	1.35mH	1.40mH	P-S:3.75KV AC, 50Hz, 5mA, 3S	P-S:100MΩ MIN	4-3:145TS	/
漏感测试 at 10KHZ 0.3V 短路其它脚Leakage Inductance Test at 10KHZ 0.3V Shorted Other Pins				P-C:1.50KV AC, 50Hz, 5mA, 3S	P-C:100MΩ MIN	6-8:70TS±0.5	
4-5		50uH MAX		C-S:3.75KV AC, 50Hz, 5mA, 3S	S-C:100MΩ MIN		
成测电感 at 10KHZ 0.3V Measured Inductance at 10KHZ 0.3V							
foot position	minimum value	midpoint	maximum values	电弧侦测 arc detection	PIN短路测试 PIN short circuit test		
4-5	1.29mH	1.35mH	1.41mH				

### 材料表 /MATERIAL LIST:

NO.	名称 ITEM	型号 TYPE	UL RATING	制造商 SUPPLERS	UL NO.
1	CORE	EE16	/	HAINING WANLI ELECTRONICS CO., LTD	N/A
2	BOBBIN	PHENOLIC T375HF	94V0 150°C	CHANG CHUN PLASTICS CO LTD	E59481
3	WIRE	2UEW 94V-0	QA-155°C	WU HU COPPER CORWN ELECTRICIAN LTD	E326270
4	TAPE	JY312Y	130°C	SUZHOU MAILADUONA ELECTRIC MATERIAL CO LTD	E188295
5	TIN	无铅107H	420°C	THOUSAND ISLAND METAL FOIL Co., LTD.	N/A
6	VARNISH	1032CJJ	155°C	QUALIPOLY CHEMICAL CORP	E213437
7	TRIPLE WIRE	TIW-B	130°C	SHENZHEN HEDONG NEW MATERIAL CO LTD	VDE40038661

制表 MADE	审核 CHECKED	批准 APPROVED	
Hufangting	RaoPing	ZhongCuilan	



## 注意事项 Matters needing attention

1、本公司产品适用于 AV 设备、OA 设备、家电、信息服务等一般电子设备中。

Our products are designed and promoted for use in general electronic devices such as audio-video equipment, office automation equipment, home appliance and information service.

2、当本公司的产品使用在一般电子设备以外的领域时，对于此所引发的设备失效我司将不承担任何法律责任。

In case of using the product for the purpose other than general electronics devices, we shall not be held liable for any dysfunctions in or damage to the equipment with which the product is used.

3、本承认书只保证我司产品作为一个单体时的质量情况，当我司产品被安装到贵公司产品上时，请贵司对使用在贵司电路上的产品情况进行了有效评价和确认。

Our specification limits the quality of the component as a single unit. Please ensure the component is thoroughly evaluated in your application circuit.

4、不要对产品施加过大的振动或机械冲击；

Do not apply excessive vibration or mechanical shock to products.

5、为防止断线，请不要使用锋利的物体接触线圈，如镊子；

Do not touch wire with sharp objects such as tweezers to prevent wire breakage.

6、在产品贴装时不要使用过大的压力，避免磁芯断裂。

Do not apply excessive stress to products mounted on boards to prevent core breakage.

7、为保证端子电极的焊接特性和包装材料处于良好状态，请于本公司发货后 6 个月内使用本产品。同时，由于端子电极的焊接特性会随时间发生变化，如果贮存时间超过 6 个月，请首先确认其焊接特性后再安装使用。

To maintain the solderability of terminal electrodes and to keep the packing material in good condition, product should be used within 6 months from the time of delivery. And the solderability of products electrodes may decrease as time passes, so in case of storage over 6 months, solderability shall be checked before actual usage.

8、存放货物的仓库应满足以下条件 Store products in a warehouse in compliance with the following condition:

条件 Conditions	元件含包装物 Packing status	元件自身 Component itself
温度 Temperature	-25~+40℃	-25~+85℃
湿度 Humidity	30~70%RH	30~70%RH

9、不要使产品遭受温度和湿度的快速变化。

Do not subject products to rapid changes in temperature and humidity.

10、不要将产品存放在化学环境中，如硫酸气体或碱性气体中，否则会降低电极端子的焊接特性和使电感器腐蚀。

Do not store the products in chemical atmosphere such as one containing sulfurous acid gas or alkaline gas, that will causes poor solderability and corrosion of inductors.

11、为了避免受潮气、灰尘等物质的影响，产品应保管于货架上。

Store products on pallets to protect from humidity, dust, etc

12、产品应避免热冲击、振动以及直接光照等等。

Avoid heat shock, vibration, direct sunlight, etc.