



产品承认书 SPECIFICATION FOR APPROVAL

客户名称:
CUSTOMER

我司料号:
OUR PART NO.

XRSQ2418-15mH-H-17215

我司品名:
OUR PART NAME

SQ flat wire inductor

送样日期:
DATE SAMPLES

数量: 0PCS
QUANTITY

制造确认 MANUFACTURER APPROVE

拟制 DRAWN	审核 CHECKED	确认 APPROVED
Hu Fangting	Tang wen	Li Zhengxiong

客户确认 CUSTOMER APPROVE

客户名称 CUSTOMER NAME:

客户料号 CUSTOMER P/N:

规格型号 DESCRIPTION: SQ2418-15mH Horizontal with 17*21.5 pin pitch

检查结果: 合格 不合格

签名及盖章:

INSPECT RESULT ACCEPT REJECT

SIGNATURE AND STAMP

说明 REMARK:

如对本承认书内容有异议请提出或标记发送至我司，本承认书在未收到异议回复时于本承认书提供一周后生效。

If you have any objection to the contents of this acknowledgment, please raise it or send the mark to us. The acknowledgment will become effective one week after the acknowledgment is provided in the absence of any objection.

东莞市祥如电子有限公司

Dongguan Xiangru Electronics Co., Ltd

Tel: 0769-86346548 Fax: 0769-86346358

Email: dgxiangru@126.com



东莞市祥如电子有限公司

SPECIFICATION FOR APPROVAL

CUSTOMER _____

CUSTOMER 'S PART NO _____

VER _____ A

DESCRIPTION SQ2418-15mH Horizontal with 17*21.5 pin pitch OUR DRAWING NO XRSQ2418-15mH-H-17215

A REVISION HISTORY

DATE OF	REVISED PROJECT	EDITION	NOTE
2019/07/22	NEEW VERSION	A	
2024/07/19	REVISION		

Page2/7

PPROVED BY	CHECKED BY	PREPARED BY	UNIT	mm
Li Zhengxi ong	TangWen	Hu Fangting	DATE	2024/07/19
			REV NO.	A

东莞市祥如电子有限公司

SPECIFICATION FOR APPROVAL

CUSTOMER _____

CUSTOMER 'S PART NO _____

VER _____

A _____

DESCRIPTION _____

SQ2418-15mH Horizontal with 17*21.5 pin pitch

OUR DRAWING NO _____

XRSQ2418-15mH-H-17215

1. APPEARANCE & DIMENSION (UNIT: mm):

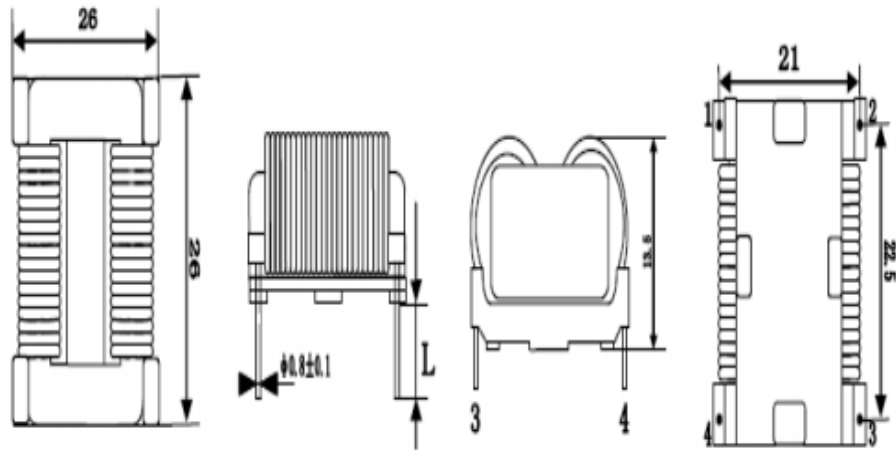

NOTE:

1. 产品共模绕制。

Product common mode winding

2. 产品需含浸凡立水固定。

The product needs to be impregnated with varnish for fixing

3. 焊点不可高于底座支点。

The solder joints must not be higher than the base support points.

Page3/7

PPROVED BY	CHECKED BY	PREPARED BY	UNIT	mm
Li Zhengxi ong	TangWen	Hu Fangting	DATE	2024/07/19
			REV NO.	A

东莞市祥如电子有限公司

SPECIFICATION FOR APPROVAL

CUSTOMER _____

CUSTOMER 'S PART NO _____

VER _____ A

DESCRIPTION S02418-15mH Horizontal with 17*21.5 pin pitch OUR DRAWING NO XRSQ2418-15mH-H-17215

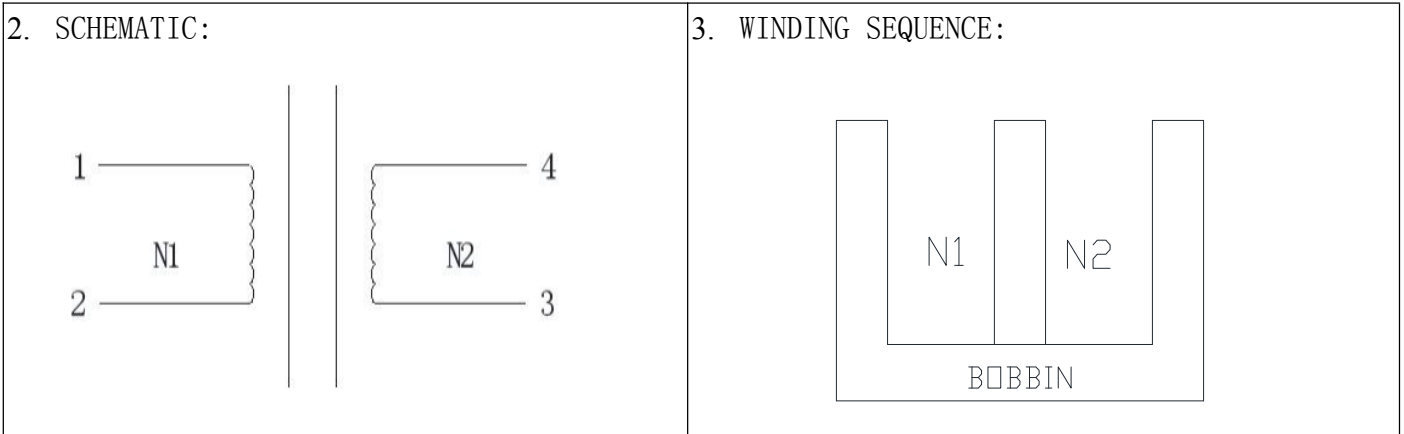

4. WINDING TABLE

ORDER	WIRE SIZE	START	END	TURNS	LAYER	INSULATION	
N1	0.2t×1.5mm UEWH FlstWire	1	2	67TS (REF)	CLOSE		
N2	0.2t×1.5mm UEWH FlstWire	4	3	67TS (REF)	CLOSE		

PPROVED BY	CHECKED BY	PREPARED BY	UNIT	mm
Li Zhengxi ong	TangWen	Hu Fangting	DATE	2024/07/19
			REV NO.	A



东莞市祥如电子有限公司

SPECIFICATION FOR APPROVAL

CUSTOMER _____

CUSTOMER 'S PART NO _____

VER _____

A _____

DESCRIPTION SQ2418-15mH Horizontal with 17*21.5 pin pitch OUR DRAWING NO XRSQ2418-15mH-H-17215

5. ELECTRICAL CHARACTERISTICS:

TEST CONDITION:		TEMPERATURE AT: 25°C ± 5°C WORKING TEMPERATURE: -25°C/+125°C STORAGE TEMPERATURE: -25°C/+40°C HUMIDITY: AT45-80% RH	
TEST INSTRUMENT	CHENHWA/1062	CHENHWA/1062	CHENHWA/502A
ITEM TERMINAL	INDUCTANCE 1KHz, 0.25Vrms 25°	DIFFERENCE INDUCTANCE 1KHz, 0.25V	DC. RESISTANCE AT 25°C
1-2	15mH MIN	0.3mH Max	100m Ω MAX
3-4	15mH MIN	0.3mH Max	100m Ω MAX
TEST INSTRUMENT	E-SUN 19053	E-SUN/19053	
ITEM TERMINAL	HI-POT TEST AC50/60Hz, 5mA, 3sec	INSULATION RESISTANCE. DC 500V	
COIL-COIL	1500V	100M Ω MIN	
COIL-CORE	1000V	100M Ω MIN	
Idc	3.0A		

APPROVED BY	CHECKED BY	PREPARED BY	UNIT	mm
Li Zhenxiong	TangWen	Hu Fangting	DATE	2024/07/19
			REV NO.	A



东莞市祥如电子有限公司

SPECIFICATION FOR APPROVAL

CUSTOMER _____

CUSTOMER 'S PART NO _____

VER _____

A _____

DESCRIPTION S02418-15mH Horizontal with 17*21.5 pin pitch OUR DRAWING NO XRSQ2418-15mH-H-17215

6. MATERIAL LIST:

No	ITEM	MATERIAL	CLASS	UL NO.	MANUFACTURER	OPT.
1	CORE	SQ2418 12K			ACMEElectronics (Guangzhou) Co;Ltd	√
		SQ2418 12K			SHANGDONG hengrui magnet technology CO.,LTD	√
		SQ2418 12K			DongGuan City JiuXin Magnetic Material Co.,Ltd	√
		SQ2418 12K			TengZhou MingJi Magnetism Industry Co., Ltd.	√
2	BOBBIN	T375HF	150°C	E59481	CHANG CHUN PLASTICS CO LTD	√
3	WIRE	@* FIWx180	180°C	E234867	SUNTEK HOLDINGS LIMITED	√
		@* UEW180	180°C	E504985	Guangdong Lizewire Electric Technology Co Ltd	√
4	VARNISH	E962	130°C	E335405	ZHUHAI CHANGXIAN NEW MATERIALS TECHNOLOGY CO LTD	√
5	tin	wuxi conditions /Sn99.9			Dongguan City Thousand Island METAL Foil CO LTD	√

Page6/7

PPROVED BY	CHECKED BY	PREPARED BY	UNIT	mm
Li Zhengxi ong	Tang Wen	Hu Fangting	DATE	2024/07/19
			REV NO.	A



东莞市祥如电子有限公司

SPECIFICATION FOR APPROVAL

CUSTOMER _____

CUSTOMER 'S PART NO _____

VER _____

A

DESCRIPTION S02418-15mH Horizontal with 17*21.5 pin pitch OUR DRAWING NO XRSQ2418-15mH-H-17215

7. THE INSPECTION REPORT

ITEM	TEXT SPEC.	1	2	3	4	5
L 值(1-2)	15mH MIN 1KHZ 0.25V 25°	15.17	15.55	16.87	19.2	22.13
L 值(3-4)	15mH MIN 1KHZ 0.25V 25°	15.17	15.55	16.87	19.2	22.13
DCR 值(1-2)	100mΩ MAX AT 25°C	OK	OK	OK	OK	OK
DCR 值(3-4)	100mΩ MAX AT 25°C	OK	OK	OK	OK	OK
HI-POT AC50/60Hz 5mA 3sec	COIL-COIL:1500V	OK	OK	OK	OK	OK
	COLI-CORE:1000V	OK	OK	OK	OK	OK

TEST EQUIPMENT

INDUCTANCE	HI-POT	DC. R
CH-3250: ()	E-SUN-19053 (√)	CH-502BC (√)
CH-1062: (√)		
CH-101: ()		

Page7/7

PPROVED BY	CHECKED BY	PREPARED BY	UNIT	mm
Li Zhenxiong	Tang Wen	Hu Fangting	DATE	2024/07/19
			REV NO.	A